

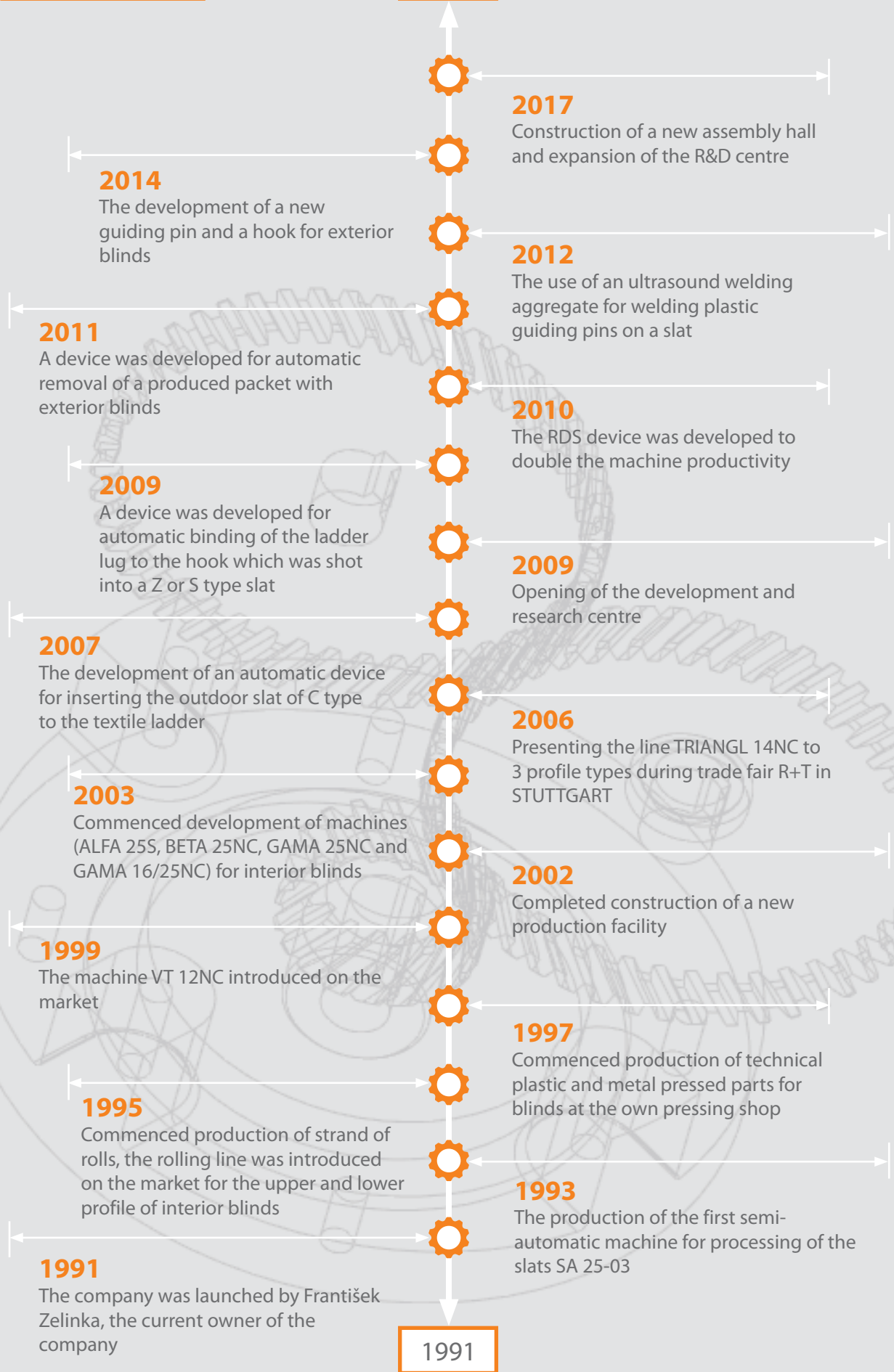

We start your innovations

**Technology
and components
for blinds**







Machines on production **Internal Venetian blinds**

The machines are intended for processing varnished aluminium strips. The machines provide shaping, cutting of required holes, cutting to the required length, or threading slats to the ladder. The blind machines are manufactured with various automation levels so as to meet the customer's requirements.

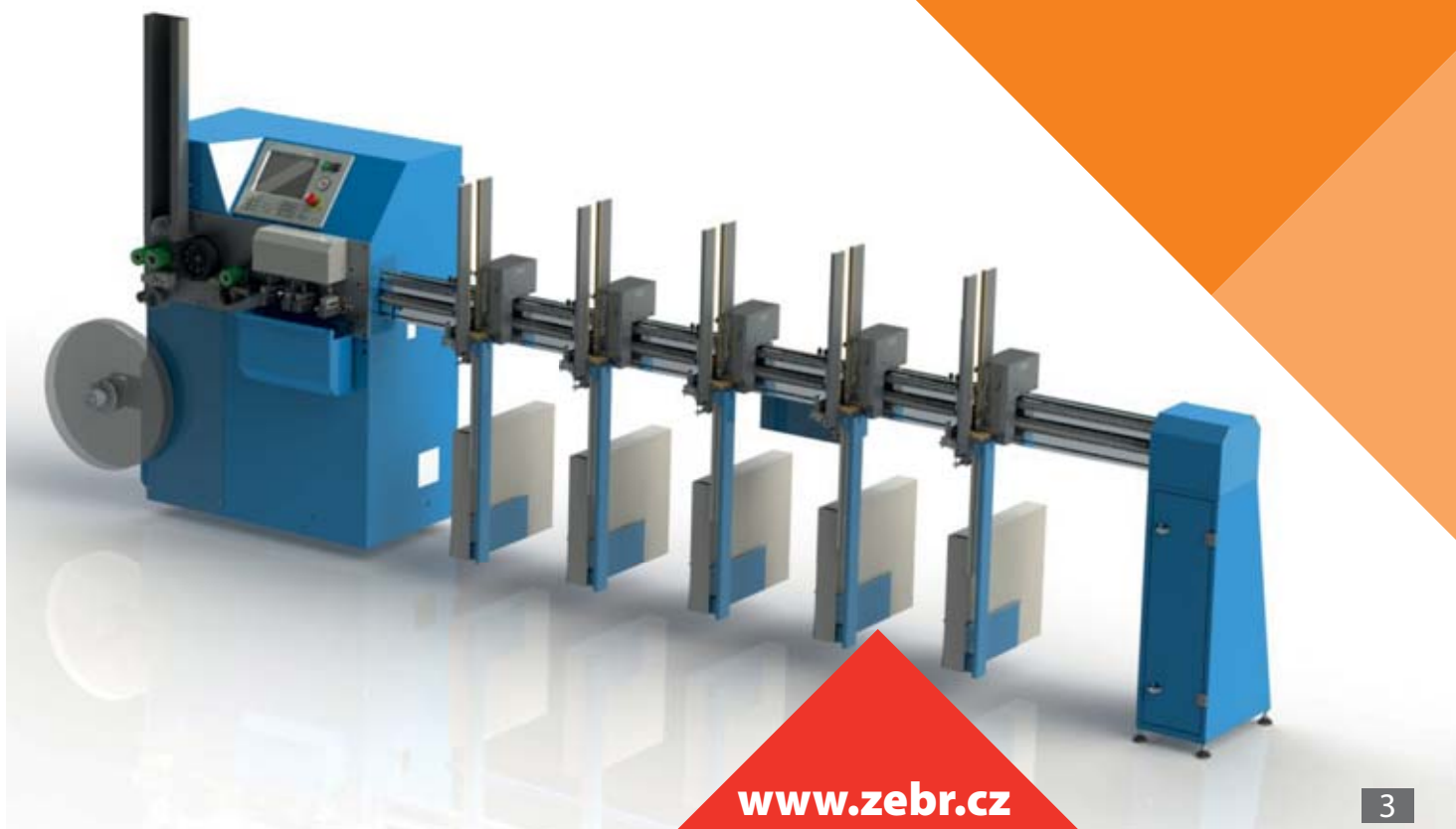

Machines on production Internal Venetian blinds

SA 25-08



- unrolling device for 1 coil
- manual spacing of punching stands
- 4 punching tools (fixing hole, texband hole - standard version)
- quick and easy feeding of slats into the machine
- quick adjustment of blind dimensions
- easy change of tools using an Allen wrench
- possibility of turning on and off the fixing holes
- punching and dividing of slats in one cycle
- continuously adjustable speed

ALFA 25S



- unrolling device for 1 coil
- **manual spacing of threading stands**
- 2 punching tools (fixing hole, texband hole - standard version)
- **quick and easy change of ladder**
- **automatic threading to ladder**
- **manual cutting of ladders**
- quick adjustment of blind dimensions
- easy change of tools using
- disposal of production waste
- **touch screen**

BETA 25S



- **unrolling device for 3 coils with manual shifting**
- manual spacing of threading stands
- **3 punching tools (fixing hole, texband hole - standard and complete-shading version)**
- quick and easy change of ladder
- manual cutting of ladders
- quick adjustment of blind dimensions
- easy change of tools using
- disposal of production waste
- touch screen

BETA 25NC



- unrolling device for 3 coils with manual shifting
- manual placement of tape
- **3 punching tools (fixing hole, texband hole - standard and complete-shading version)**
- quick and easy change of ladder
- **automatic feeding of slats into the machine (optionally)**
- **automatic spacing of threading stands**
- **automatic burning out and sealing of ladder**
- quick adjustment of blind dimensions
- easy change of tools using
- disposal of production waste
- touch screen

Machines on production Internal Venetian blinds

BETA 50NC

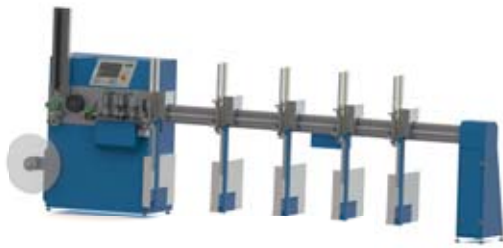

- unrolling device for 1 coil
- manual placement of tape
- 3 punching tools (fixing hole, texband hole - standard and complete-shading version)
- automatic spacing of threading stands
- automatic threading of a slat into the ladder
- burning through of ladder (standard)
- quick adjustment of blind dimensions
- disposal of production waste
- touch screen

BETA 16/25NC



- unrolling device for 3 coils (1 x 16mm, 2 x 25mm) with manual shifting
- manual placement of tape
- 3 punching tools (fixing hole, texband hole - standard and complete-shading version)
- automatic feeding of slats into the machine (optionally)
- automatic spacing of threading stands
- automatic burning out and sealing of ladder
- quick adjustment of blind dimensions
- disposal of production waste
- touch screen

GAMA 25NC



- **unrolling device for 3 coils with pneumatic shifting**
- 3 punching tools (fixing hole, texband hole - standard and complete-shading version)
- **automatic feeding of slats into the machine**
- 4 hole types in one tool
- automatic spacing of threading stands
- automatic burning out and sealing of ladder
- quick adjustment of blind dimensions
- disposal of production waste
- touch screen

GAMA 16/25NC



- unrolling device for 3 coils (1 x 16mm, 2 x 25mm) with pneumatic shifting
- 3 punching tools (fixing hole, texband hole - standard and complete-shading version)
- automatic feeding of slats into the machine
- automatic spacing of threading stands
- automatic burning out and sealing of ladder
- quick adjustment of blind dimensions
- **2 types (16 mm) + 4 types (25 mm) of holes in one machine**
- disposal of production waste
- touch screen

	Number of coils in the hopper	Automatic inserting of the strip	Shaping of the tape	Number of punching stations / number of hole types	Threading of the slat into the ladder	Position of the threading stands	Ladder burning	Productivity	Connection to the intranet	Service, diagnostics, statistics	Touch screen
SA 25 - 08	1	—	•	4/1	—	—	—	45 slats/min	—	—	—
ALFA 25S	1	—	•	2/1	•	manual	—	180 packets/8 hours	•	•	•
BETA 25S	1	—	•	3/1	•	manual	—	270 packets/8 hours	•	•	•
BETA 25NC	3	option	•	3/1	•	automatic	•	350 packets/8 hours	•	•	•
BETA 50NC	1	—	•	3/1	•	automatic	•	350 packets/8 hours	•	•	•
BETA 16/25 NC	1 (16mm) 2 (25mm)	—	•	3/1	•	automatic	•	350 packets/8 hours	•	•	•
GAMA 25NC	3	•	•	3/4	•	automatic	•	370 packets/8 hours	•	•	•
GAMA 16/25NC	1 (16mm) 2 (25mm)	•	•	3/4	•	automatic	•	350 packets/8 hours	•	•	•

Additional devices for the production internal Venetian blinds

RSU 25-09



- simple manual machine for the cutting and punching of the upper and lower profiles
- possibility of adding an additional tool (e.g. cover etc.)
- easy maintenance
- high tool lifetime

HSP 25-10



- hydraulic device for the cutting of the lower and upper profiles
- module system of individual tools
- possible variants of extension
- easy change of modules using an Allen wrench
- possibility of adding an additional tool (e.g. cover etc.)
- low noise level during operation
- easy maintenance
- high tool lifetime

CLX 1 DUO



- line for the rolling of upper and lower profiles for horizontal interior blinds
- two active unrolling devices with ultrasonic sensor
- punching of all necessary holes in profiles
- dividing of profiles to the required size
- inserting of the plastic bearing into the upper profile
- marking of the upper profile using Laser-JET or INK-JET technology with the possibility of bar-code printing
- stacking table
- possible custom or length production
- machine productivity: 1 m long profiles with three holes with grooved plastic bearings up to 10 seconds



Machines on production **External blinds**

Rolling lines intended for the production of horizontal exterior blinds for the processing all types of common slats. The exterior blind machines enable full automation of the overall production process and at the same time they offer a unique method of solution for any customer.

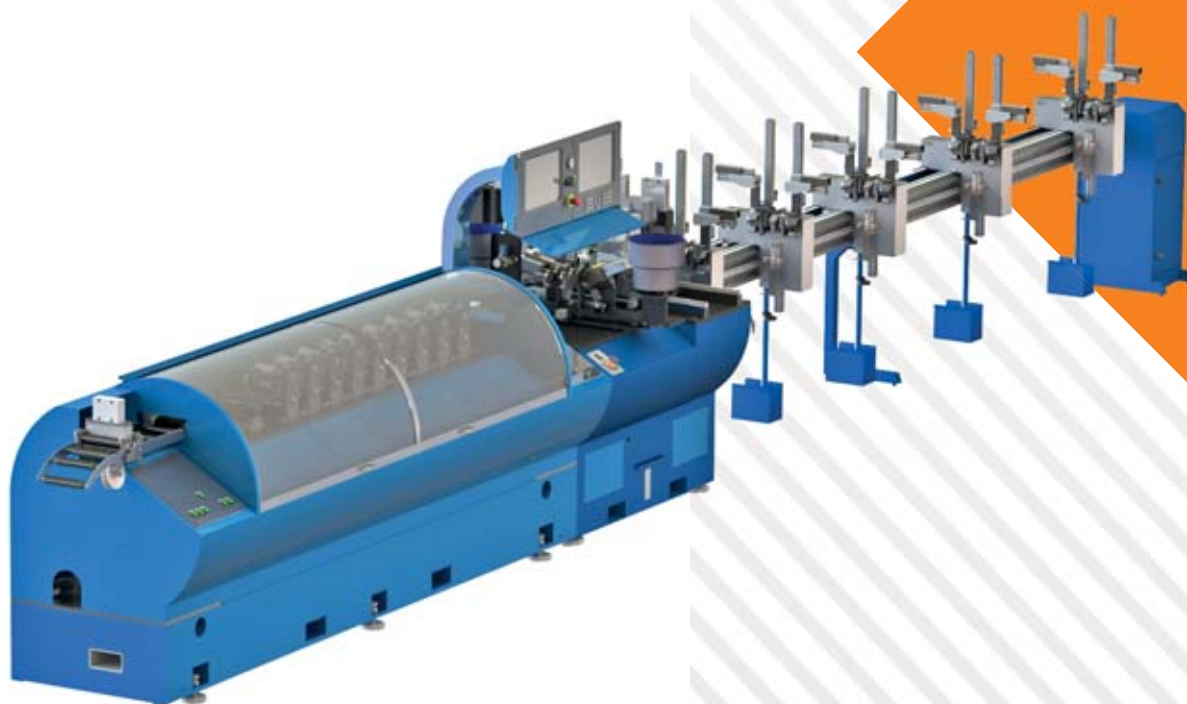

Machines designed for new producers

Without the possibility of later automation

VT 12 NC START

A single-purpose rolling line for the production of one horizontal exterior blind - type C80 or Z90. The VT 12NC START model is designed as an affordable alternative for starting or small manufacturers. Later upgrade of this machine is not possible.

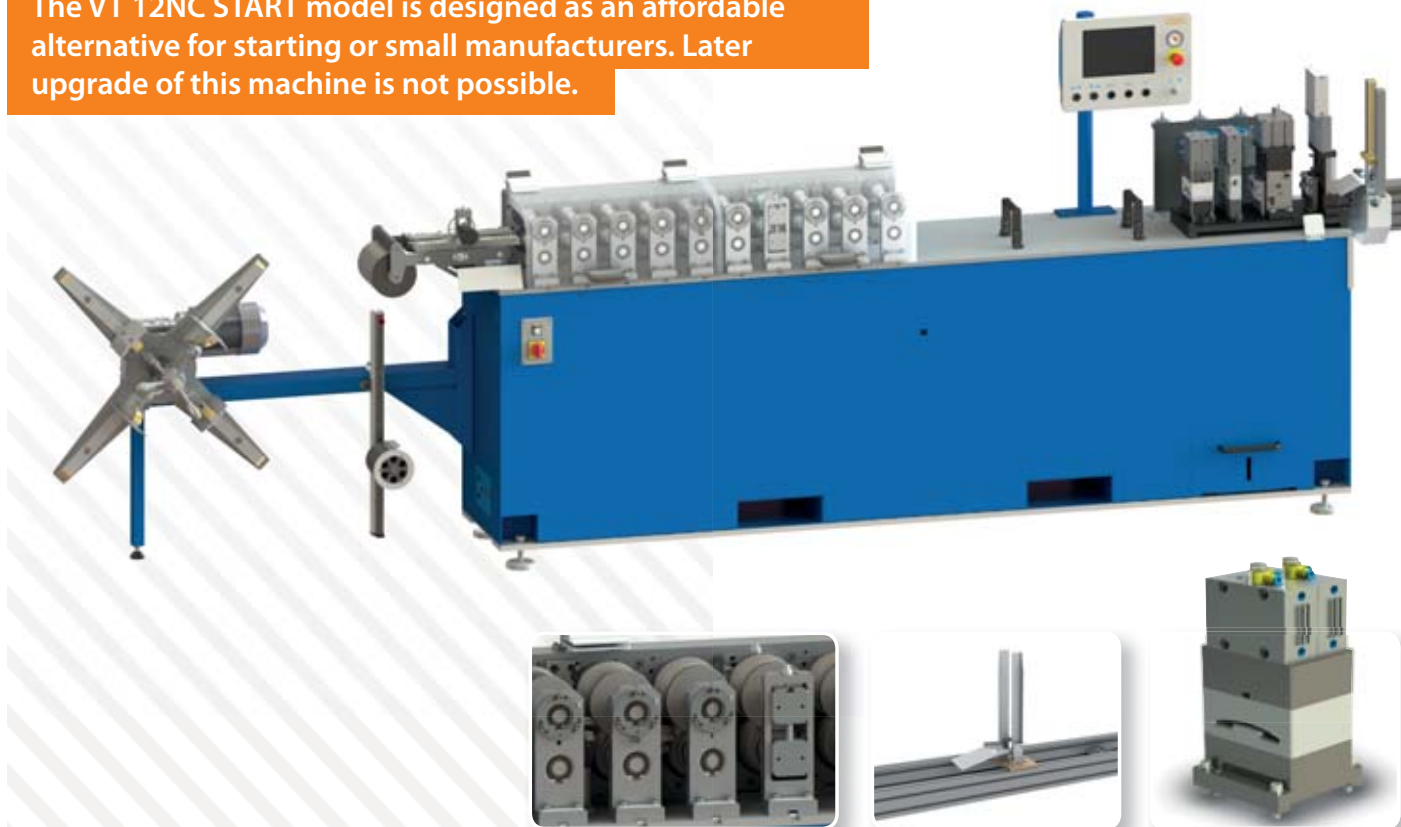

Characteristics

- integrated device for unrolling aluminium sheet
- set of rolling wheels
- tool for punching holes for TEXBAND and fixation
- cutting tool
- modem for remote diagnostics of machines
- stacking table with manually adjustable stacking stands
- control system with a touch panel with a connection to the intranet
- simple entering of dimensions for manufactured slats
- central tool lubrication system

Optional accessories

Fixation of guiding pins

• Manual inserting of guiding pins

- metal as well as plastic into the pre-punched holes

• HNK I

Simple hydraulic device for pressing the metal guiding pins into the horizontal exterior blinds.

- manual inserting of the slat
- simple inserting of the guiding pins
- possible riveting for all profile types
- quality differentiation of the rivets
- easy maintenance
- guarantee of continuing distinguishing using a hydraulic aggregate

• Pliers for riveting the guiding pins

Shooting of hooks

- optional pneumatic device for the closing of hooks
- optional manual device for the closing of hooks



A single-purpose rolling line for production of 2 profile types of horizontal exterior blinds C, S, Z or Flach (according to the customer's requirements). For this model you can choose at the beginning the option of semiautomatic and gradually move to a fully automated version.

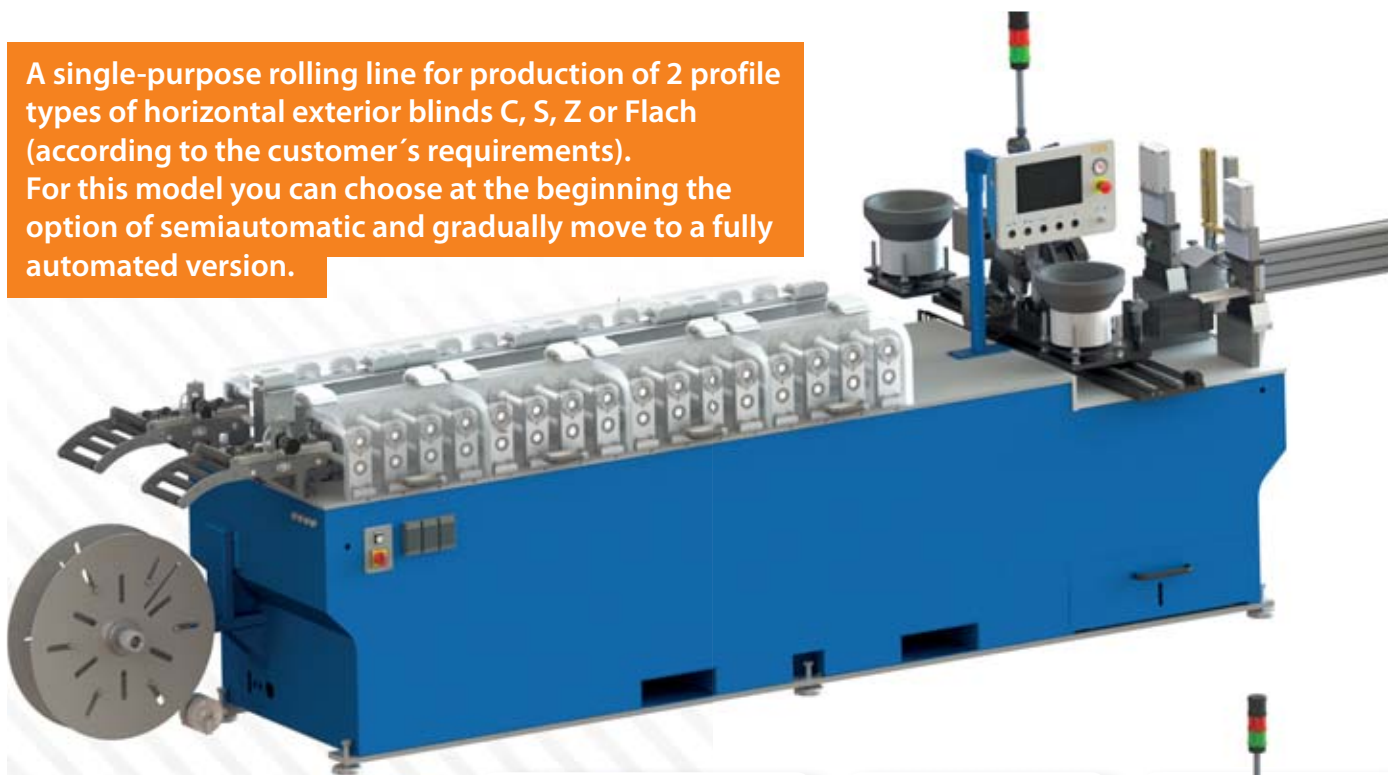

Characteristics

- integrated device for unrolling aluminium sheet
- 2 sets of rolling wheels
- tool for punching holes for TEXBAND
- tool for punching of various holes for guiding pins or side guiding
- cutting tool
- cutting-out of fixing hooks for ladder cord fixing
- shooting of flat or HAGOFIX hooks with slats of type Z or S
- rolling-in of the sealing rubber with slats of type Z or S (including the possibility of fixation)
- stacking table with manually or automatically adjustable stacking stands
- central tool lubrication system
- control system with a touch panel
- simple entering of dimensions for manufactured slats
- easy adjustment of rolling speed
- two production modes STANDARD and ATYP

A - TYPE – Optional setting of punching holes position on the slat. Positions can be defined by entering the exact value.

STANDARD – Automatic setting of punching holes position on the slats depending on the size of the slat.

Benefits

- two machines in one - saving space, time and finances
- increase of product quality
- saving time and material (due to the absence of the need to change the rolling wheels)
- automatic ultrasonic welding of plastic guiding pins
- implementing the automatic riveting device for metal guiding pins
- automatic threading of slats of type C or FLACH to the ladder



Machines with optional full automation

VT12 NC

A single-purpose rolling line for production of one horizontal exterior blind of type C, S, Z or Flach (according to the customer's requirements). For this model, at the beginning you can choose the option of semi-automatic version and gradually move to a fully automated version.

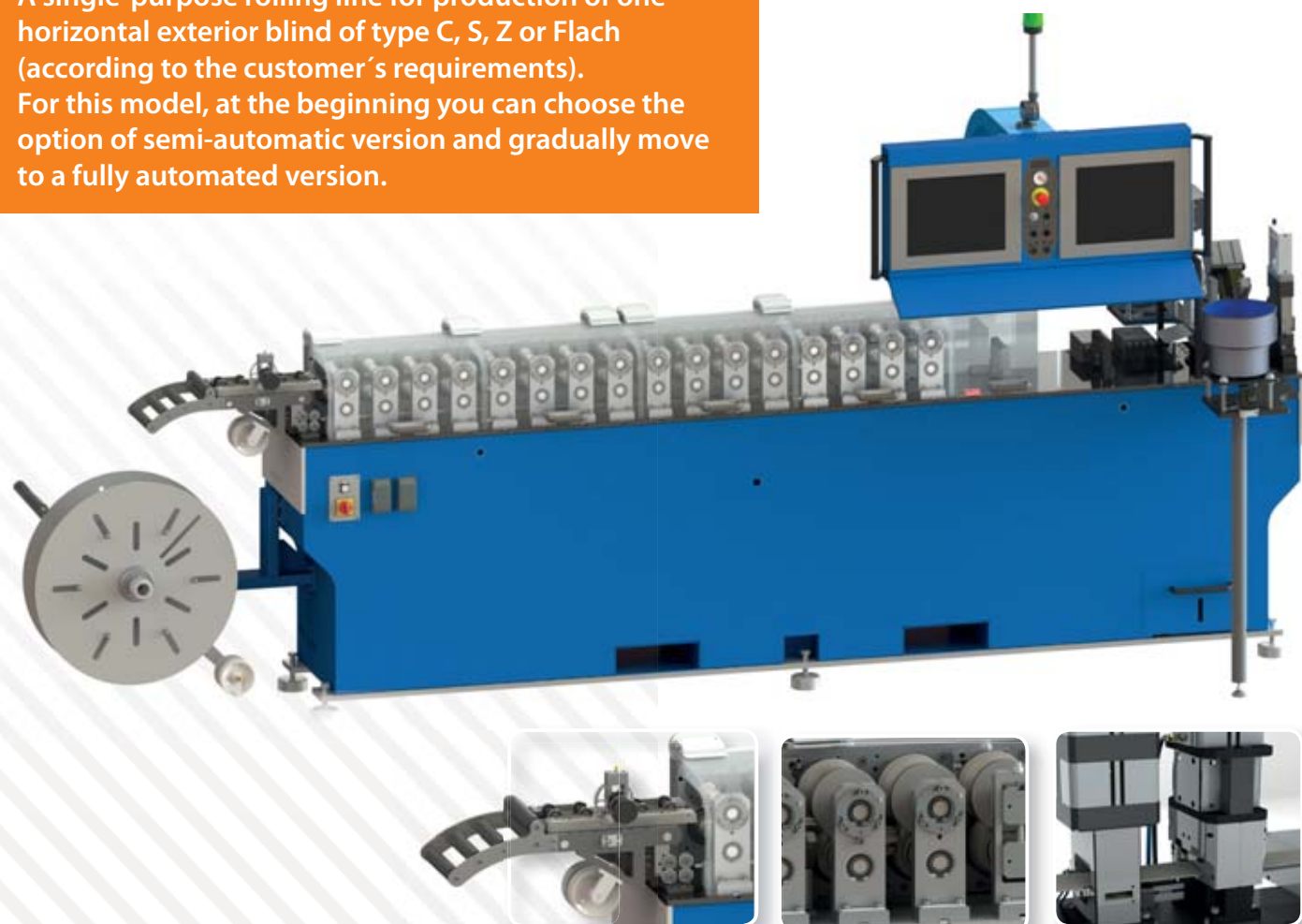

Characteristics

- integrated device for the unrolling of an aluminium sheet
- set of rolling wheels
- tool for punching holes for TEXBAND
- tool for punching of various holes for guiding pins or side guiding
- cutting tool
- cutting-out of fixing hooks for ladder cord fixing (with slats of type C and FLACH)
- shooting of flat or HAGOFIX hooks with slats of type Z or S
- rolling-in of the sealing rubber with slats of type Z or S (including the possibility of fixation)
- stacking table with manually or automatically adjustable stacking stands
- central tool lubrication system
- control system with a touch panel
- simple entering of dimensions for manufactured slats
- easy adjustment of rolling speed
- two production modes STANDARD and ATYP

A - TYPE – Optional setting of punching holes position on the slat. Positions can be defined by entering of the exact value.

STANDARD – Automatic setting of punching holes position on the slats depending on the size of the slat.

Benefits

- increase of product quality
- noticeable savings in production costs through automation and high productivity
- reducing the amount of the waste and defective products
- production of complete packets in one machine
- modem for remote diagnostics of machines
- connection of the machine to the company's intranet
- connecting to the ETHERNET network
- RDS mode - allows for the increase of productivity and efficiency of the production by 100% in comparison with the machines with standard configuration

Possible variants of extension - see the optional accessories for VT 12NC and TRIANGL 14NC



A single-purpose rolling line for production of up to 3 slat types of horizontal exterior blinds C, S, Z or Flach (according to the customer's requirements).

The transformation of rolling wheels is performed by turning the whole worktable with, including the reconstruction of all working parts.



Characteristics

- unrolling device
- 3 sets of rolling wheels
- tools for punching holes for TEXBAND
- tool for punching of various holes for guiding pins or side guiding
- pneumatic cutting tool
- cutting-out of fixing hooks for ladder cord fixing with slats of type C and FLACH
- shooting of flat or HAGOFIX hooks with slats of type Z or S
- rolling-in of the sealing rubber with slats of type Z or S (including the possibility of fixation)
- stacking table with automatically adjustable stacking stands
- central tool lubrication system
- control system with a touch panel
- simple entering of dimensions for manufactured slats
- two production modes STANDARD and ATYP

A - TYPE – Optional setting of punching holes position on the slat. Positions can be defined by entering the exact value.

STANDARD – Automatic setting of punching holes position on the slats depending on the size of the slat.

Benefits

- increase of product quality
- noticeable savings in production costs through automation and high productivity
- reducing the amount of the waste and defective products
- fast transition from one profile to another
- saving time and material (due to the absence of the need to change the rolling wheels)
- turntable for three different profiles
- production of complete packets in one machine
- modem for remote diagnostics of machines
- connection of the machine to the company's intranet
- connecting to the ETHERNET network
- RDS mode - allows for the increase of productivity and efficiency of the production by 100% in comparison with the machines with standard configuration

Possible variants of extension - see the optional accessories for VT 12NC and TRIANGL 14NC



Optional accessories for machines VT 12NC and TRIANGL 14NC

Unrolling device

- single



- double



- horizontal



Cutting

- possible cutting of the sheet to the required width

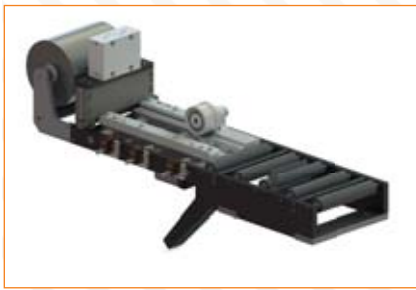

Marking of the slats

- printer for labels with an applicator
- INK-JET
- laser
- imprinting of the logo on the slat



Shooting of hooks

- optional pneumatic device for the closing of hooks
- optional manual device for the closing of hooks



Final assembly of the slats

- threading device - for slats of type C and F



- binding device - for slats of type S and Z with a grooved hook



Conveyor

- compartment



- belt



Handling the final packet

- manual removing of the final packet
- automatic removing of the final packet using the arms of the manipulator to the chosen type of conveyor

Fixation of guiding pins

- Pliers for riveting the guiding pin



S and Z profiles



C and F profiles



- universal for all profile types



• Manual inserting of guiding pins

- metal as well as plastic into the pre-punched holes



• Ultrasonic welding of plastic guiding pins



• HNK I

Simple hydraulic device for pressing the metal guiding pins into the horizontal exterior blinds.



- manual inserting of the slat
- simple inserting of the guiding pins
- possible riveting for all profile types
- quality differentiation of the rivets
- easy maintenance
- guarantee of continuing distinguishing using a hydraulic aggregate

• Pliers for manual closing the fixation hooks





This is an independent automatic machine processing rolled packets of exterior slats. ZK Completo model offers a solution for customers who want to expand existing facilities with the new technology. This device has been designed as a modular system to meet specific customer requirements.

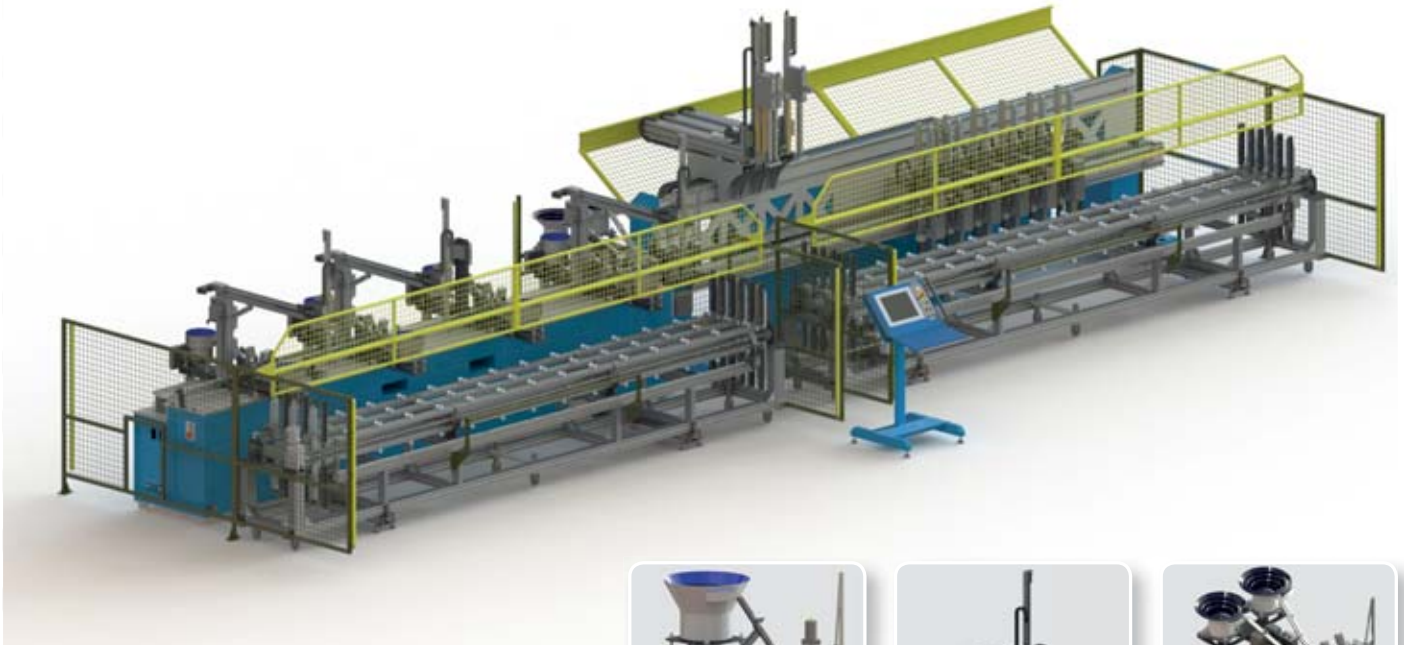

Characteristics

- automated loading and handling of slats
- operation on customer request
- stacking table

Benefits

- increase of product quality
- noticeable savings in production costs through automation and high productivity
- reducing the amount of the waste and defective products
- modem for remote diagnostics of machines
- connection of the machine to the company's intranet
- connecting to the ETHERNET network

Possible variants of extension

Marking of the slats

- printer for labels with an applicator
- INK-JET
- laser
- imprinting of the logo on the slat

Shooting of hooks

- possible shots of fixation hooks into the slats of types C, Z, S

Fixation of guiding pins

- Riveting of metal pins
- Ultrasonic welding of plastic pins

Final assembly of the slats

- threading device - for slats of type C and F
- binding device - for slats of type S and Z with a grooved hook

Handling the final packet

- manual removing of the final packet
- automatic removing of the final packet using the arms of the manipulator to the chosen type of conveyor

Conveyor

- compartment
- belt



A single-purpose rolling line for the production and processing of horizontal exterior blinds upper profile.

The model VT 12NC HP allows for the processing of profiles in two ways: direct entry of dimensions into the machine according to a job order or only the production of profiles in the length specified for further processing.



Characteristics

- unrolling device
- set of rolling wheels
- stacking table with automatic shifting of the rolled profile

Benefits

- punching of required holes
- dividing of the profile to the required length
- wasteless processing of profiles
- possibility of product marking using Laser-JET or INK-JET technology or using the bar code label
- automatic insertion of plastic bearings into profiles
- connecting to the ETHERNET network
- connection of the machine to the company's intranet
- modem for remote diagnostics of machines



HSP 50NC

Separate automatic device that processes an already rolled or extruded top profile for exterior horizontal blinds.

The model HSP 50NC allows to process the top profile to the required length with different hole variables and the number of pieces produced.



Characteristics

- manual inserting of the profile
- automatic shifting of the inserted profile
- automatic processing accordant to the entered parameters
- stacking table



Components for **Interior blinds**

We are the producer and supplier of all components required for production of interior blinds (in standard or all-shading design).

We have developed our own low-noise blind system ZEUS, which is intended for plastic as well as wooden windows, with the reduced number of components.

The blind system ZEUS is made in two design variations - straight or round. We offer also selected components for older types of blinds (ISO).



Universal sun – blind system with elegant design

- minimal number of used components
- easy assembly
- high quality of execution and used materials
- modern and elegant design
- possibility to select standard and complete-shading version
- wide colour range - white RAL 9016, brown RAL 8014, silver RAL 9006, wood imitation RAL 8003
- possibility to insert a slat transmission (brake)
- possibility of quick change of flat slat type to round (stylish) one with change to a couple of components only
- possibility of production all necessary tools for manufacturing of the profiles for blinds
- possibility of supplying automatic and semi-automatic machines for slat cutting with threading into ladders



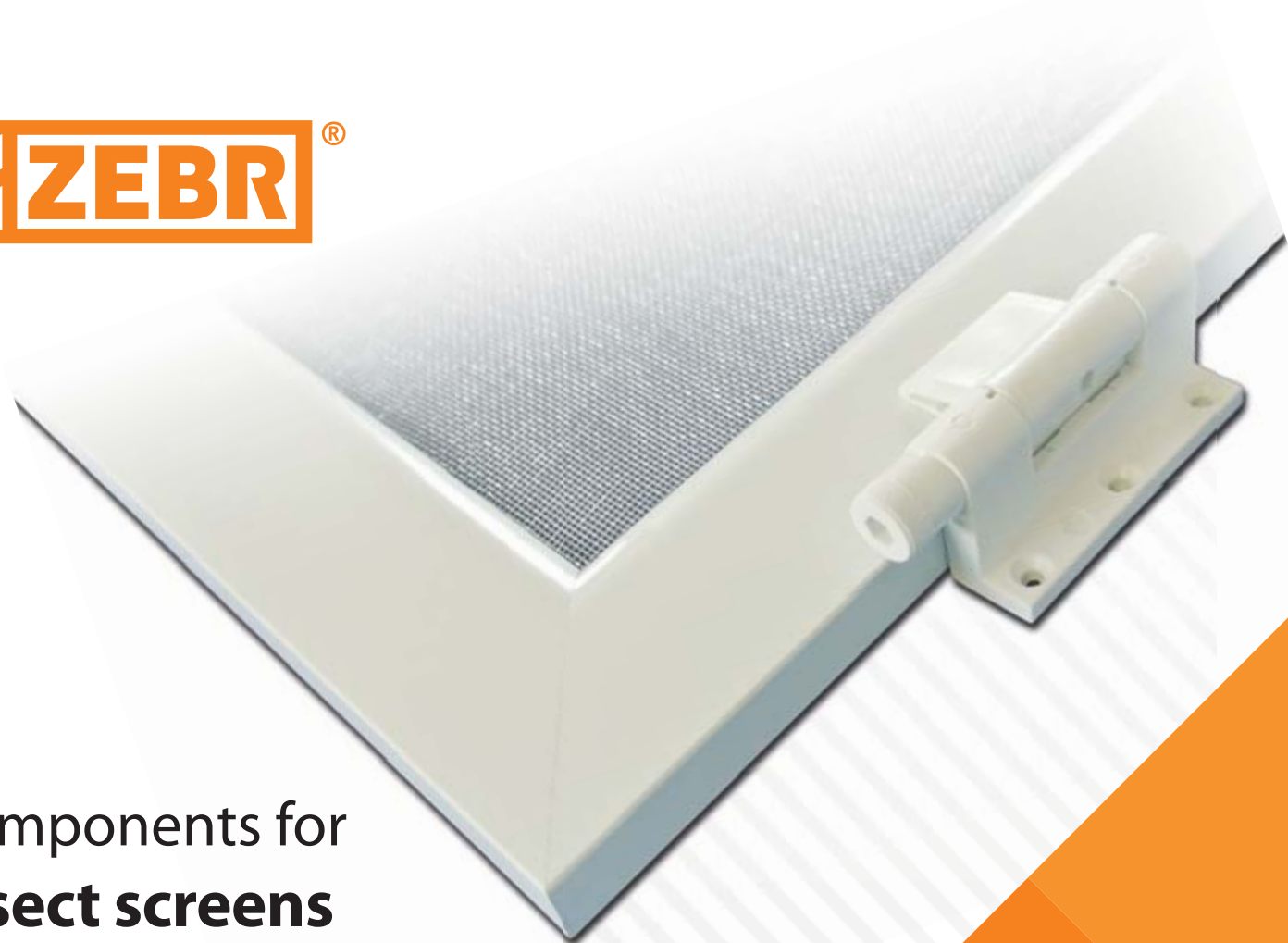

Components for insect screens

We are the producer and supplier of components required for the production of fixed insect screens. We offer rolled aluminium profiles for window as well as door screens, including plastic mouldings and metal stampings and other accessories.

Thanks to several types of window profiles - of various shapes and colours, it is possible to choose the most convenient variant for a selected window type.

Sliding doors



Insect screens system



Door profile
50 x 20 x 5000 mm



Door profile R18
51 x 18 x 5000 mm



Window profile STANDARD
25 x 10 x 5000 mm



Window profile LEM
31 x 12 x 5000 mm



Window profile R50
33 x 11 x 5000 mm

Product features

- roll-formed aluminium profile
- two side RAL painting with hot varnished structure
- perfect mechanical features
- possibility of atypical shapes
- sealing brush for dust protection and noise absorbing
- left or right door opening
- easy assembly and maintenance

Offered standard RAL colours

- white RAL 9003
- brown RAL 8019
- anthracite RAL 7016
- silver RAL 9006
- wood imitation
- walnut
- golden oak

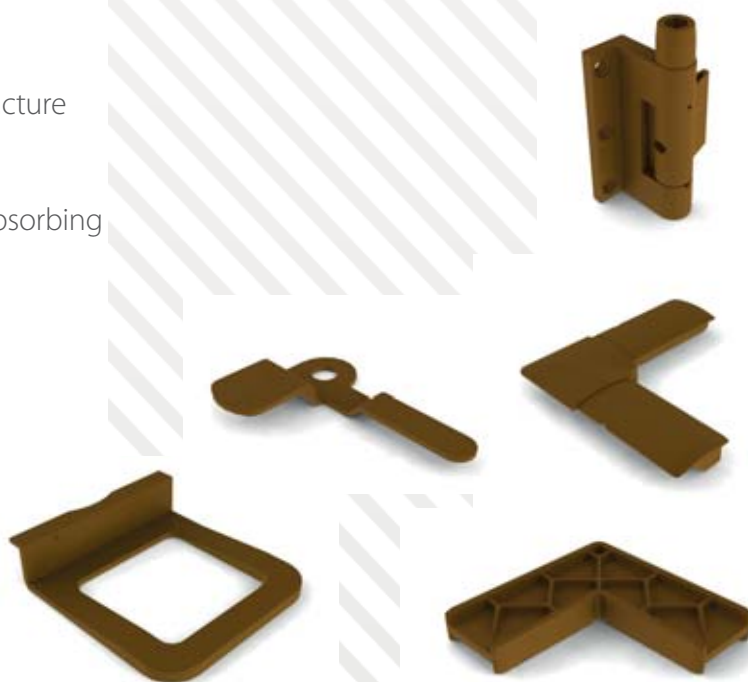



Components for **External blinds**

We are the producer and supplier of selected components required for production of exterior blinds. We offer selected components, such as side seals for lower profiles, plastic and metal pins, nailing hooks for slat profiles, sealing gum or gum into the guiding rails.

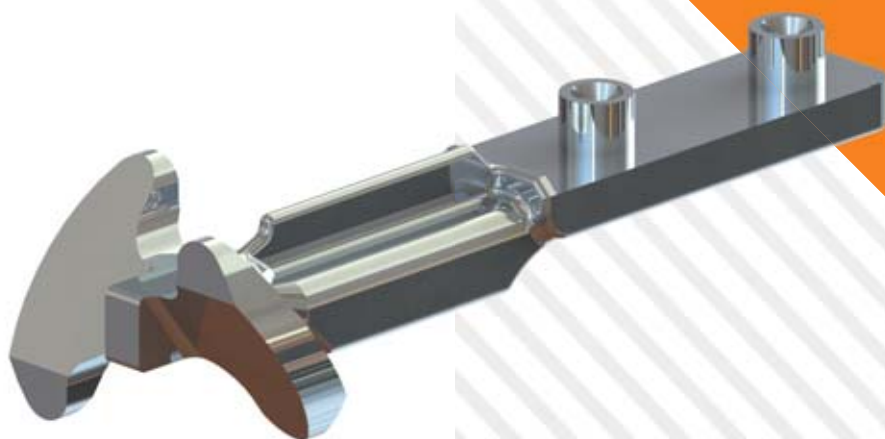

Plastic side caps for bottom rail (weights)

- quality plastic materials for outdoor use
- possibility of company logo fitting
- wide colour range
- possibility of shape customization



Metal guiding pins and universal hooks

- universal guiding pin for all types of slats and a universal hook
- guiding pins for slats of types C, FLACH, S and Z
- surface treatment for outdoor use
- designed for automated riveting process
- possibility of individual side cap development
- designed in cooperation with external blinds manufacturers

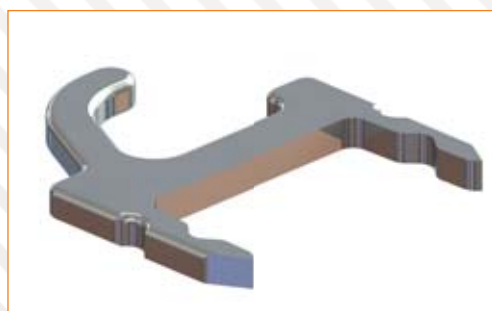

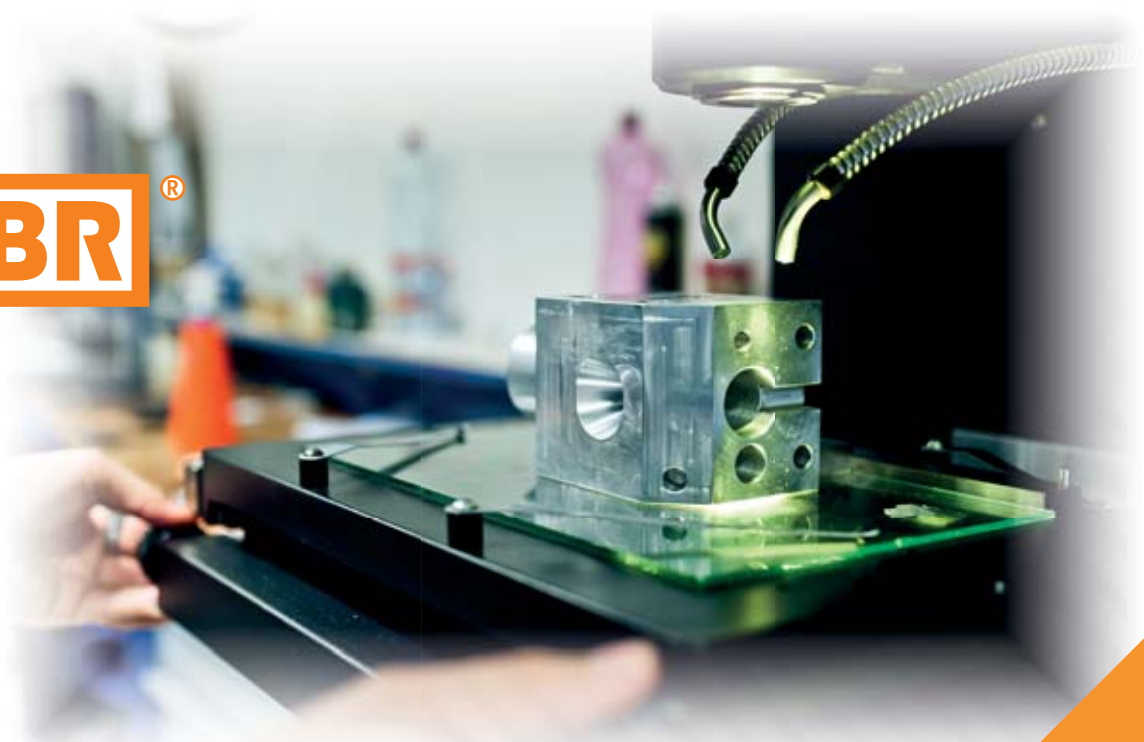

Other technologies



Prototyping

Development of moulded pieces

3D printing

Prototype injection moulding device

- possibility to test a pre-series and small-series production on a small device with low costs for mould production
- injection moulding from technical plastic materials such as ABS, ASA, PA 6, POM, PS, PC, PP, PE
- lifecycle of aluminium mould for hundreds of pieces
- design and construction of the aluminium mould in our tool shop
- optional colour variants, UV stabilizing agents, and other additives

Vacuum injection moulding in silicone moulds

- production of complex moulded pieces (negative skews, thin-walled models, and more)
- low mould purchase costs



Plastic injection

Production of injected plastic parts. Used materials: PA 6, ABS, PS, ASA, POM, PE, PC etc.

- price calculation (product, moulding)
- development and cooperation in the production of new moulds
- creation of pre-production prototypes - rapid prototyping
- mould design, mould construction, mould maintenance
- sampling, design of materials and colours
- pressing plastic parts and elements
- assembly of plastic parts, other handling activities



Sheet part pressing

- production of sheet parts used for interior blinds and insect screens
- zinc and powder coating in co-operation with external suppliers
- colour shades: white, ocher, brown, zinc
- assembly and packaging of metal parts



Roll-forming

- profile production according customers drawings
- aluminium sheet processing up to 0.5 mm thickness
- aluminium sheet processing up to 0.7 mm thickness

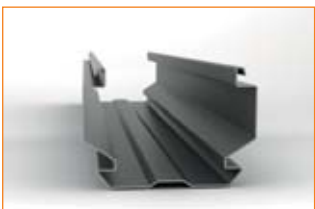



ZEBR TECHNOLOGICAL PARTNERSHIPS

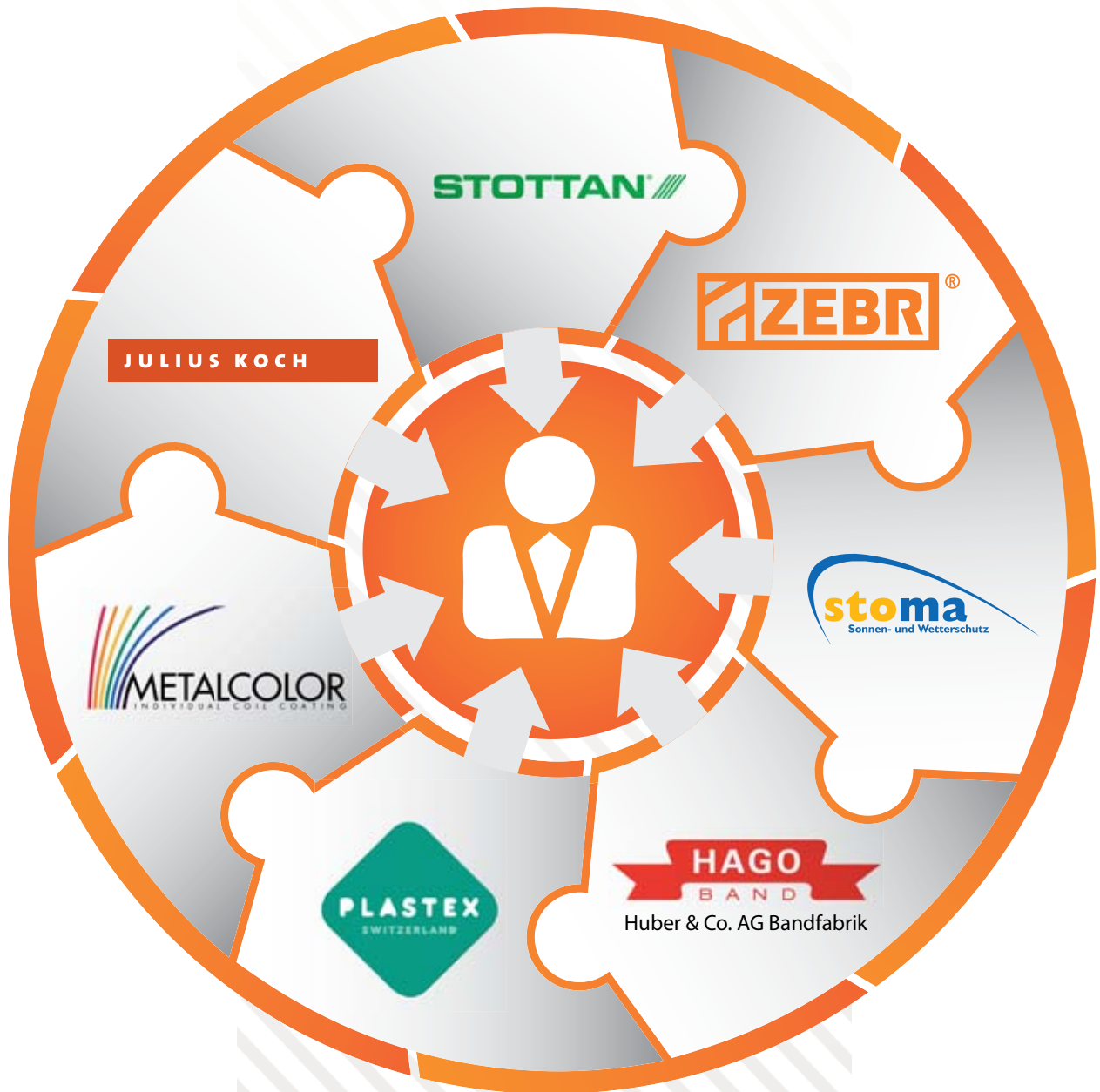

ZEBR CERTIFICATION



We start your innovations



Germany

Poland

Prague

Czech Republic

Brno



Slovakia

Austria

Vienna Bratislava

ZEBR s.r.o.
Milovice 178, 691 88
Czech Republic
Telephone: +420 519 515 810
Fax: +420 519 515 813
Mobile: +420 777 753 551
E-mail: info@zebr.cz

www.zebr.cz

